

Adjustable Pedestals

Technical Datasheet

Height and slope adjustable pedestal systems for raised external flooring. Engineered to support pavers and decking, and to reduce construction costs, conceal services, and enable a fast and effective installation.

- Unaffected by moulds or algae
- Good resistance to alkali and bitumen
- Manufactured from Polypropylene
- 100% recyclable

WORKS AS PART OF THE RAAFT TERRACE SYSTEM

Our range of height adjustable decking and paving pedestals are easy to use and engineered for high performance.

While they have been designed to complement the Terrafina and Atria external flooring systems, they also work with other types of decking, tiling and paving.

It provides a cavity for services to be concealed and improves heat and sound insulation.

Facilitates rapid surface drainage whilst allowing waterproofing and services to remain accessible.

Made from 100% recycled materials and supports Green Building certification.

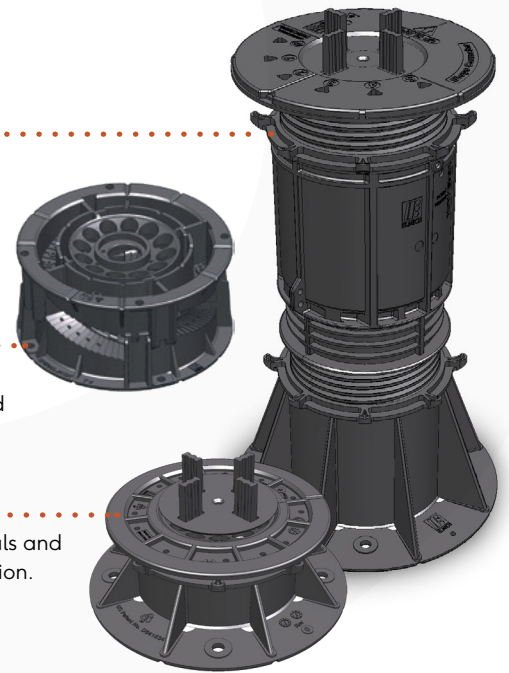

PRODUCT INFORMATION

HEIGHT	12-18mm	17-23mm	23-29mm	30-44mm	44-50mm	57-75mm	81-117mm	124-210mm	204-281mm
PLEASE NOTE: The pedestal to joist connector adds an extra 3mm to your build-up height.									
Code	311010	311011	311012	311013	311016	311017	311018	311019	311020
Base diameter	155mm			190mm			205mm		
Ultimate compressive strength	20Kn				15Kn				

A Structural Engineer should always be consulted when constructing a raised floor.

Although the pedestals are very strong and have a high structural strength, please be aware that the surface they are laid on needs to be taken into account as well. Extreme heavy static loads can cause pedestals to sink into rigid insulation over time and therefore the amount of support needs to be significantly increased in these situations to increase the spread the load to suit the substrate according to its performance.



FIND OUT MORE OR REQUEST A SAMPLE

e: technical@raaft.co

w: raaft.co

© 2021 Raaft Ltd.

At the time of writing and publication of the sheet, all information is specified correctly. The company reserves the right to change the specifications of this product at any time without prior notice to third parties. Any images and diagrams used in this sheet are intended only as illustrations. No rights can be derived from them.

Adjustable Pedestals

Technical Datasheet

ACCESSORIES

ACCESSORY	USE	PRODUCT CODE
Top slope corrector	For correcting slopes between 0-5% with pedestals under 300 mm in height	312020
Base Slope Corrector	For correcting slopes up to 5° for pedestals over 300 mm	312021
Spacer Tab 3 mm/H15 mm		312010
Spacer Tab 6 mm/H15 mm	For installing tiles directly onto pedestals	312011
Spacer Tab 8 mm/H15 mm		312012
Pedestal to joist connector	For connecting the Raaft joists to the pedestals (please note this adds an extra 3mm to the height)	312014
Rubber accoustic shim 1mm		312016
Rubber accoustic shim 2mm	These are used to level unbalanced tiles and absorb sound.	312017
10mm Wall spacer unit	For creating a fixed buffer between tiles and adjacent upstands/walls	312025

APPLICATIONS

Raaft Adjustable Pedestals are engineered to provide a versatile and cost-effective solution to support raised pavers and decking on external terraces, roof gardens, balconies and podium areas. Typically used with man-made products such as porcelain tiles and composite decking, the pedestals can also be used with natural stone slabs and timber decking however please be aware of the increased tolerances with these surfaces.

INSTALLATION INFORMATION¹

Please refer to the Raaft Adjustable Pedestal Installation Guide on the product page on raaft.co.

STORAGE & HANDLING

The product is securely packed into cardboard boxes to ensure no movement of the product in transit. Depending on the size/weight of the consignment this may be palletised.

Whilst there is no specific weight restrictions on what is or is not safe to lift in manual handling, an assessment of the health and safety risks should be undertaken and measures taken to reduce the risk of injury so far as reasonably practicable.

The following guidelines may be useful:

- Each person should be fully trained in manual handling techniques.

- The use of handling aids such as a trolley, folk-lift, pallet truck or conveyor should be used if moving large volumes of cartons.
- Break up large consignments into more manageable loads.
- Ensure that the product is stored at a reasonable height, so avoiding the lifting of cartons from floor level or above shoulder height.
- Reduce carrying distances of cartons.

PROTECTIVE EQUIPMENT

We recommend that PPE (Personal Protective Equipment) is used when installing Joists:

- Good strong safety boots/shoes to protect the feet.
- Protective eyewear such as safety glasses.
- Strong gloves to protect the hands.
- If using loud cutting equipment then ear plugs or defenders should be worn.

ENVIRONMENTAL ISSUES

Raaft Adjustable Pedestals are manufactured from polypropylene and is 100% recyclable. As a result the whole life cost of a polypropylene pedestal system is excellent as it is sold for recycling not paid disposal.

FIRE PROTECTION

Joists are made using Aluminium Alloy 6063A T6 which does not burn and is not a fire hazard.



FIND OUT MORE OR REQUEST A SAMPLE

e: technical@raaft.co

w: raaft.co

© 2021 Raaft Ltd.

At the time of writing and publication of the sheet, all information is specified correctly. The company reserves the right to change the specifications of this product at any time without prior notice to third parties. Any images and diagrams used in this sheet are intended only as illustrations. No rights can be derived from them.

Adjustable Pedestals

Technical Datasheet

FIRST AID

The Health and Safety Regulations 1981 require all construction sites to have the following:

- a) A first aid box with enough equipment to cope with the number of workers on site.
- b) An Appointed Person to take charge of first-aid arrangements. The Appointed Person looks after first aid equipment and facilities and calls the emergency services when required. Appointed Persons do not need first aid training.
- c) A First-Aider who has undertaken training and holds an HSE approved qualification to administer first-aid. This means that they must hold a valid certificate of competence in either: First aid at work (FAW) issued by a training organisation approved by HSE, Emergency first aid at work (EFAW) issued by a training organisation approved by HSE, A recognised Awarding body of Ofqual/Scottish Qualifications Authority.
- d) The number of first-aiders will depend on the site.
- e) Information should be clearly displayed on site telling workers the name of the Appointed Person(s) or First Aider(s) and where to find them.

STABILITY

Polypropylene is a tough, high performance polymer with good chemical and fatigue resistance, making it exceptionally suitable for commercial adjustable pedestal systems.

SUPPORTING DOCUMENTS

More information on the Raaft Adjustable Pedestal products can be found at raaft.co on the product page. In particular, look for the Technical Support documents.

1. The **Installation Information** given in this document is intended as a guide only. We recommend that professional opinions are obtained before work is commissioned. Raaft Ltd accepts no responsibility for any damage or loss as a result of using the **Installation Information**. We will be happy to engage in any discussion with regard to specific project applications.



FIND OUT MORE OR REQUEST A SAMPLE

e: technical@raaft.co

w: raaft.co

© 2021 Raaft Ltd.

At the time of writing and publication of the sheet, all information is specified correctly. The company reserves the right to change the specifications of this product at any time without prior notice to third parties. Any images and diagrams used in this sheet are intended only as illustrations. No rights can be derived from them.